

Since the usage and finishing of the product is not under our control, we accept no liability for the success of the work and can therefore only guarantee the nature of our products as per the accompanying product data sheets and in accordance with our general terms and conditions of sale. The properties listed here represent no guarantee with respect to the eventual use of our products. We reserve the right to make changes due to technical advances. Any other technical information given in the course of a consultation must be confirmed in writing. Colours shown here are restricted by the printing techniques and may differ from those exhibited by the products themselves. We also reserve the right to make alterations to the product technology or design. Only the current version of this data sheet is valid. Such versions are accessible by anyone via the internet. The issue of the latest data sheet invalidates all those that have been published beforehand.

DURALIS RELIEF LINE

1/2

Decorative and dividing profiles made of natural / high gloss polished

- Information Sheet -

DURAL

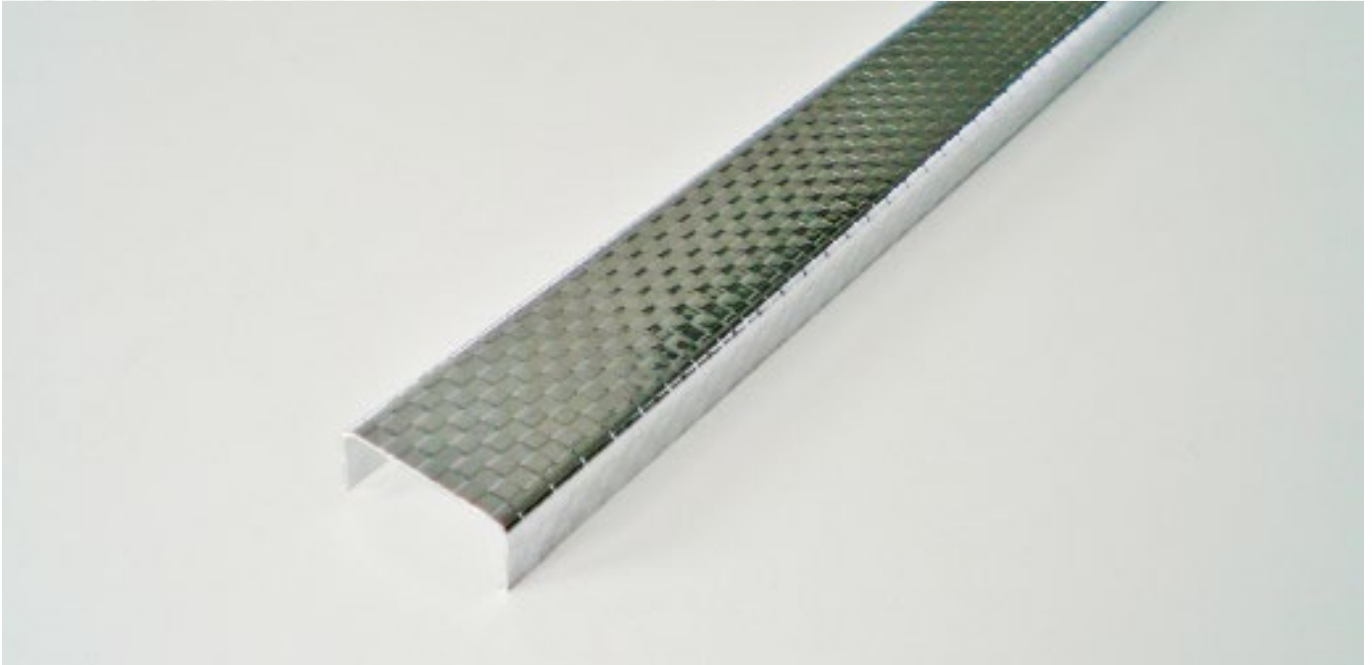

APPLICATION:

DURALIS RELIEF LINE profiles from Dural are decorative “Listello” profiles, which have been developed for the attractive design of walls and floors. They are particularly attractive and give rooms that extra touch of individuality. The edging profiles have a visible surface 25 mm wide.

DURALIS RELIEF LINE stainless steel profiles are particular suitable for applications where the profiles are subject to a high degree of stress. They also fulfil the utmost mechanical demands.

MATERIAL:

DURALIS RELIEF LINE profiles are made of natural or high gloss polished stainless steel. They should be cut to length using a hacksaw with a fine saw blade or with suitable stationary machine saws. When using angle grinders, special blades for cutting stainless steel should be used and you should carefully monitor the speed of the blade to ensure that the profile does not turn blue. Profiles should always be cut at right angles to the width of the profile so that they abut cleanly to any uncut profiles: Cut edges of profiles should have any burrs removed where necessary. Inside and outside corners need to be carefully mitred.

For all products and materials, the following applies: The suitability of the material with regard to the expected mechanical loading and chemical exposure must be investigated carefully in each individual case. The generally recognised rules of good engineering practice must always be observed!

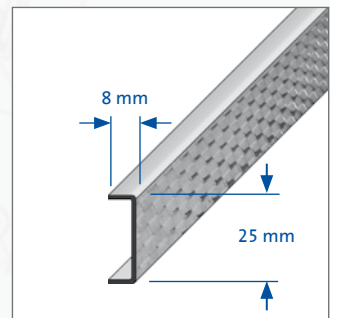
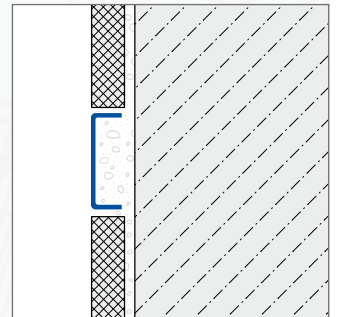

DURAL GmbH

Südring 11

D-56412 Ruppach-Goldhausen

Tel. +49 (0) 2602/9261-0

Fax +49 (0) 2602/9261-50

info@dural.com

Decorative and dividing profiles made of natural / high gloss polished

- Information Sheet -

INSTALLATION:

1. For walls, determine the right height to install the decorative profile or work to the relevant designs.
2. Install above the top row of tiles having applied a suitably thick layer of tile adhesive, which conforms to DIN 12004 of quality class C2/S2. Alternatively, tile adhesive can be applied to the reverse of the DURALIS RELIEF LINE profile. The back of the profile must have been treated with a primer designed for non-absorbent surfaces. Make sure that it has dried sufficiently.
3. Push the DURALIS RELIEF LINE profiles into the adhesive until the top surface is flush with the surface of the tiles.
4. Profiles should be laid in a straight line and with no gaps between them.
5. A gap of 2–3 mm should be left alongside the profiles.
6. Afterwards the next layer of tiles can be laid.
7. The joint between tiles and profile can be filled using non-abrasive mortar in the course of normal grouting of the tiles. If necessary, the joint can also be sealed with neutral-cure silicone.

MAINTENANCE:

For stainless steel profiles, the use of chrome polish is recommended. This gives a shiny finish. Cleaning agents must be free of damaging hydrochloric acid, hydrofluoric acid or any other aggressive additives and must not cause scratches to the surface of the profiles. For regular cleaning, suitable cleaning agents for use can be neutral or only slightly acidic or alkaline and if necessary, they may contain solvents. When cleaning walls using cement stain remover, suitable measures must be taken to prevent it coming into contact with the profiles to stop corrosion of the metal. Polishing with a dry linen cloth will also add to the glossy effect of the profile surface.

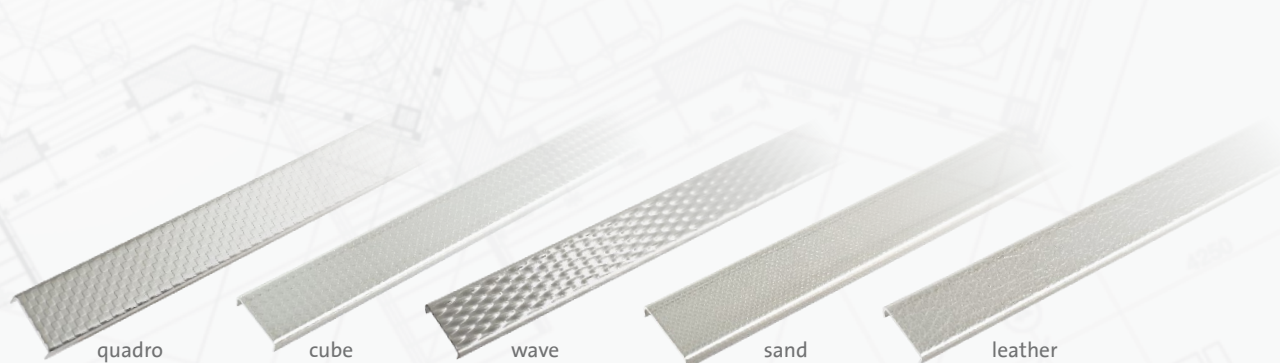

PRODUCT DATA:

MATERIAL:	Stainless steel natural / high gloss polished (5 surfaces)
LENGTH OF PROFILE:	250 cm
VISIBLE WIDTH:	25 mm
HEIGHT OF PROFILE:	8 mm
APPLICATION:	Decorative profile for walls and floors

DURAL GmbH

Südring 11

D-56412 Ruppach-Goldhausen

Tel. +49 (0) 2602/9261-0

Fax +49 (0) 2602/9261-50

info@dural.com