

Since the usage and finishing of the product is not under our control, we accept no liability for the success of the work and can therefore only guarantee the nature of our products as per the accompanying product data sheets and in accordance with our general terms and conditions of sale. The properties listed here represent no guarantee with respect to the eventual use of our products. We reserve the right to make changes due to technical advances. Any other technical information given in the course of a consultation must be confirmed in writing. Colours shown here are restricted by the printing techniques and may differ from those exhibited by the products themselves. We also reserve the right to make alterations to the product technology or design. Only the current version of this data sheet is valid. Such versions are accessible by anyone via the internet. The issue of the latest data sheet invalidates all those that have been published beforehand.

# DURAFLEX

1/2

## Expansion joint profiles in hard-soft PVC for use with the thick-bed process

- Information Sheet -

**DURAL**



### APPLICATION:

DURAFLEX thick-bed expansion joint profiles from Dural have been developed in order to prevent tension due to pressure on a flooring surface. They are used as dividers for stone-based surfaces (clinker pavings, ceramic tiles, natural stone pavings). With the soft section in the model, they absorb tensions due to pressure and damp them with no difficulty. This also prevents breakages to the pavings themselves.

The hard PVC exterior ensures that DURAFLEX thick-bed profiles also provide efficient protection for edges. Better protection for edges can only be achieved by using other materials (e.g. brass, stainless steel - see DURAFLEX TL range). The flexible form means that the profiles can also be installed subsequently to the rest of the paving. They can easily be used for subsequently generated expansion joints. DURAFLEX thick-bed profiles are available in heights of up to 65 mm. Their suitability for the function is also attested by a special certificate (Säurefließner Vereinigung e.V., D-30938 Großburgwedel).

### MATERIAL:

DURAFLEX thick-bed profiles are made of environmentally-friendly hard-soft PVC. They are available in the following colours: white, beige, black, terracotta, grey, grey/transparent.

### PROPERTIES:

DURAFLEX thick-bed profiles are mainly designed for use in industry. They are made using coloured PVC and are largely UV-resistant. Their usage with regard to chemical and mechanical resistance should nevertheless be assessed in each individual case.

N.B.: The use of coloured mortar with ultra fine colour pigments in conjunction with plastic profiles may result in permanent staining of the profiles. We recommend taking appropriate protective measures as a precaution.

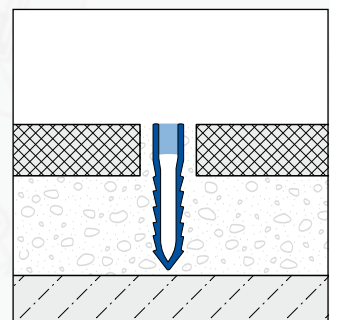
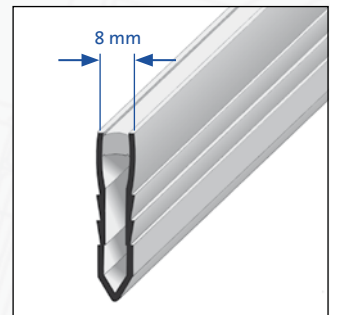

**DURAL GmbH**

Südring 11

D-56412 Ruppach-Goldhausen

Tel. +49 (0) 2602/9261-0

Fax +49 (0) 2602/9261-50

info@dural.com

EXP 06/2015

Resistant to chemicals

Weather-resistant

Light stress

Medium stress

Heavy stress

[www.dural.com](http://www.dural.com)

## Expansion joint profiles in hard-soft PVC for use with the thick-bed process

- Information Sheet -

For all products and materials, the following applies: The suitability of the material with regard to the expected mechanical loading and chemical exposure must be investigated carefully in each individual case. The generally recognised rules of good engineering practice must always be observed!

### INSTALLATION:

1. DURAFLEX thick-bed profiles appropriate to the height of the tiles should be selected.
2. Profiles should be placed flush with the surface and laid thus. Contact mortar should be used to ensure that the profiles are thoroughly embedded at the sides.
3. The adjoining surface should be moved flush against the profile and fully embedded in the mortar.
4. Any space between the profile and the tiles should be filled completely with grout.

### MAINTENANCE:

DURAFLEX thick-bed profiles do not require any special maintenance. Dirt may be removed using conventional cleaning agents. Cleaning agents should be free of hydrochloric and hydrofluoric acid and should not contain abrasives.

### PRODUCT DATA:

MATERIAL:	PVC
COLORS:	white / beige / black / terracotta / grey / grey-transparent
HEIGHT:	30 / 35 / 40 / 50 mm (65 mm only grey)
WIDTH:	8 mm
LENGTH:	250 cm

DURAL GmbH  
Südring 11  
D-56412 Ruppach-Goldhausen  
Tel. +49 (0) 2602/9261-0  
Fax +49 (0) 2602/9261-50  
info@dural.com