

Since the usage and finishing of the product is not under our control, we accept no liability for the success of the work and can therefore only guarantee the nature of our products as per the accompanying product data sheets and in accordance with our general terms and conditions of sale. The properties listed here represent no guarantee with respect to the eventual use of our products. We reserve the right to make changes due to technical advances. Any other technical information given in the course of a consultation must be confirmed in writing. Colours shown here are restricted by the printing techniques and may differ from those exhibited by the products themselves. We also reserve the right to make alterations to the product technology or design. Only the current version of this data sheet is valid. Such versions are accessible by anyone via the internet. The issue of the latest data sheet invalidates all those that have been published beforehand.

# DURACOVE

1/2

## Concave profiles or stainless steel wall and floor skirting

- Information Sheet -

**DURAL**

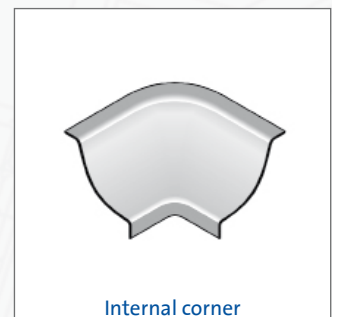
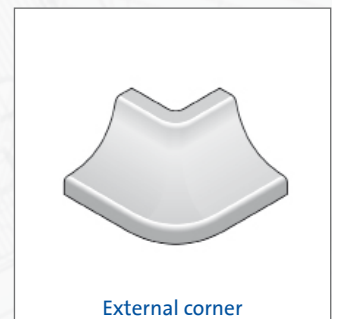
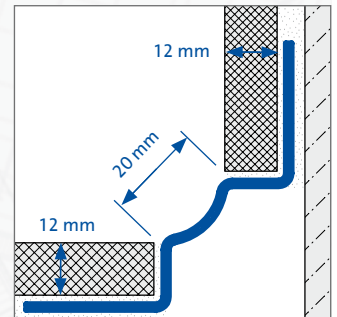

### APPLICATION:

Stainless steel DURACOVE concave skirting profiles from Dural are the perfect skirting between walls and floors. The profiles should be used wherever hygiene and quick-and-easy cleaning are important, e.g. in hospitals, public toilet facilities, industrial kitchens or in the foodstuff industry.

DURACOVE stainless steel profiles are concave and quarter-circular in shape, and are available with base legs of equal heights. Special attention must be paid to any necessary expansion grouting and sound conduction requirements. The special profile can be used for wall-floor or wall-wall skirting (internal corners). Internal and external corner pieces are also available.

### MATERIAL:

DURACOVE stainless steel concave skirting profiles are made of stainless steel brushed mat V2A.

### PROPERTIES:

Because they are concave, DURACOVE stainless steel profiles are particularly easy to clean, offer a high level of hygiene and functionality, and have an attractive appearance. They are resistant to mechanical stress and to most chemicals. In cases of exposure to particularly high mechanical or chemical stress, suitability must be assessed on a case to case basis.

DURAL GmbH  
Südring 11  
D-56412 Ruppach-Goldhausen  
Tel. +49 (0) 2602/9261-0  
Fax +49 (0) 2602/9261-50  
info@dural.com

## Concave profiles or stainless steel wall and floor skirting

- Information Sheet -

### INSTALLATION:

Apply tile adhesive to the entire surface around the profile leg perforations. Do not grout the surface behind the concave section of the profil.

For internal corners use the appropriate corner pieces and attach these flush with the remaining profile and without grout. Lay floor and wall tiles such that they are flush with the edges of the concave section of the profiles. Leave spacing of approx. 2 mm between profile and adjacent tiles. Grout the end joint or provide flexible joint as required.

For all products and materials, the following applies: The suitability of the material with regard to the expected mechanical loading and chemical exposure must be investigated carefully in each individual case. The generally recognised rules of good engineering practice must always be observed!

### MAINTENANCE:

DURACOVE stainless steel concave profiles generally do not require special cleaning. They are resistant to mould/mildew and bacteria and satisfy all hygiene requirements. During routine cleaning, the profiles should be cleaned with suitable agents. Generally warm water and a few drops of any detergent will suffice.

Cleaning agents must not contain hydrochloric or hydrofluoric acid. Before using a cleaning agent, make sure that the manufacturer explicitly confirms its suitability or use on stainless steel.

### PRODUCT DATA:

<b>MATERIAL:</b>	Stainless steel brushed mat V2A
<b>PROFILE WIDTH (DIAGONAL):</b>	20 mm
<b>HEIGHT:</b>	12 / 12 mm
<b>MATERIAL THICKNESS:</b>	1 mm
<b>PROFILE LENGTH:</b>	250 cm
<b>ACCESSORIES:</b>	Moulded parts for internal and external corners

DURAL GmbH  
Südring 11  
D-56412 Ruppach-Goldhausen  
Tel. +49 (0) 2602/9261-0  
Fax +49 (0) 2602/9261-50  
info@dural.com